

Radar MultiView RMV RMV-G2

Operating and installation manual

EN Version 1.0

Measuring radar motion detector
for energy efficient opening of
automatic gate systems



Operating and installation manual

EN Version 1.0

Order designation: measuring radar motion detector for energy efficient opening of automatic gate systems.

Art.Nr. 10001337

Table of content

1. Safety instructions	3
2. Scope of delivery and device description	4
2.1 Scope of delivery	4
2.2 Device description	4
3. Installation	7
3.1 Installation	7
3.2 Wiring	8
3.2.1 Connectors	6
3.2.2 Wiring	9
4 Set-up	10
4.1 Function signaling	10
4.2 Radar function areas	10
4.3 Parameterization via the sensor's own web portal	10
4.4 Commissioning the radar	11
4.4.1 Connecting the radar and mobile device	11
4.4.2 Settings on the web browser interface	11
4.5 Angle settings	12
5. Operation	12
5.2 Overview of LED display	12
6. Maintenance	12
7. ESD safety	13
8. Decommissioning	13
9. Disposal	13

Sensotek GmbH

Sales Partner within the Pepperl+Fuchs Group

Stuttgarter Str. 119, 73061 Ebersbach (Fils), Germany

Tel.: +49 7163 93926-0, Fax: +49 7163 93926-10, info@uk.sensotek.com

1. Safety instructions

Personnel qualifications

The activities described in this document may only be carried out by qualified personnel.

Persons designated as "professionals" have appropriate technical training and experience with the technology and use. Professionals using their skills to identify and minimize risks to themselves and others when carrying out actions. The conditions specified by the manufacturer and applicable standards and regulations must be observed by the professional when carrying out actions.



Disconnect the electrical circuit before installing or servicing the device.

The device may only be operated with safety extra low voltage that complies with the Safety Extra Low Voltage (SELV) requirements in the safety standards based on IEC 60950.

EC Declaration of Conformity – Extract

Sensotek GmbH

Stuttgarter Str. 119

73061 Ebersbach (Fils), Germany

hereby declares that the product described is in accordance with the provisions of the listed EC directives and that the standards and/or technical specifications have been applied, referred to below.

Directives

2014/53/EU Radio equipment

2011/65/EU RoHS

The technical documentation is available at info@uk.sensotek.com

Harmonized European standard, national rule:

EN 300 440 V2.2.1:2018

EN 301 489-1 V 2.2.3:2019

EN 301 489-3 V 2.1.1:2019

EN 62368-1:2014+AC:2015

EN IEC 63000:2018

UKCA Declaration of Conformity – Extract

Sensotek GmbH

Stuttgarter Str. 119

73061 Ebersbach (Fils), Germany

hereby declares that the product described is in compliance with the provisions of the listed directive(s) and that the standards and/or technical specifications referred to below have been applied.

Directives:

Radio Equipment Regulations 2017

RoHS, The Restriction of the Use of Certain Hazardous Substances in Electrical and Electronic Regulation 2012

The technical documentation is available at info@uk.sensotek.com

Harmonized European standard, national rule:

EN 300 440 V2.2.1:2018

EN 301 489-1 V 2.2.3:2019

EN 301 489-3 V 2.1.1:2019

EN 62368-1:2014+AC:2015

EN IEC 63000:2018

2. Scope of delivery and device description

2.1 Scope of delivery

- Radar MultiView RMV-G2

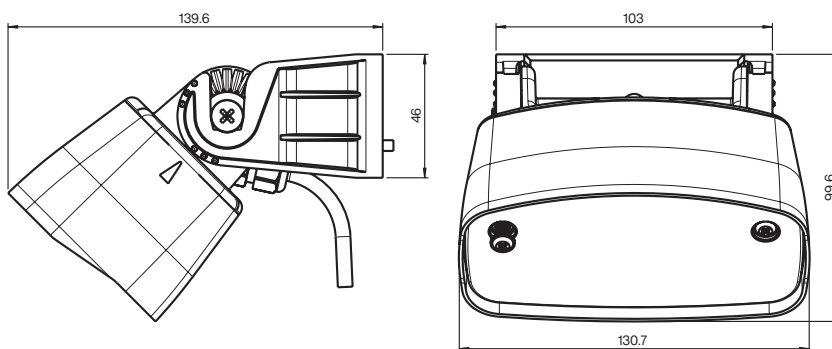

- Operating manual
- QR Code and SSID on the housing of the RMV-G2; for establishing the connection to the web server; see chapter 4.4.1
- Password for initial login on the RMV-G2 housing; for logging in to the web server; see chapter 4.4.2
- Drilling template
- 2 x screws (tapping screws)
- 1 x wire harness, 8 wire cord, 10 m length with 8-pin plug

2.2 Device description

The intelligent measuring 2-D-Radar MultiView RMV/D2 enables energy efficient opening of automatic gates by precisely determined time and duration of opening based on five input parameters (movement, direction, speed, distance, angle), which are processed inside the intelligent radar unit.

According to customer requirements, an activation area can be defined individually, with a maximum of 8 points in the form of a polygon.

Activation areas are the key to perfectly functioning gates. On the one hand, only desired movement events in a defined activation area triggers the gate and, on the other hand, actions of moving objects outside the activation field are suppressed.

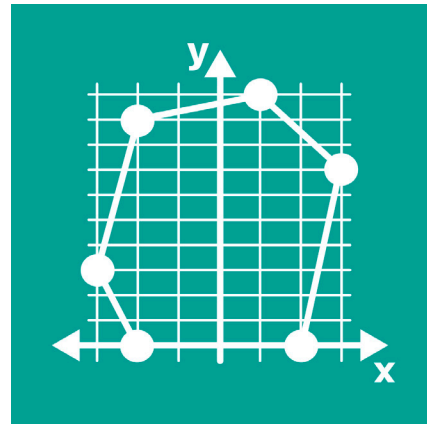

A near area directly in front of the gate can be used to force continuous opening.

Sensors are **parameterized** via an in the sensor integrated web server using any smartphone or tablet.

Installation is mainly reduced to simply mounting the devices on the hinge and opposite hinge side above the gate. With the integrated web server, subsequent optimization can be carried out securely without requiring a ladder. This means that installation can be completed in just a few steps.

The **cloning function** enables quick set-up of several identical installation points.

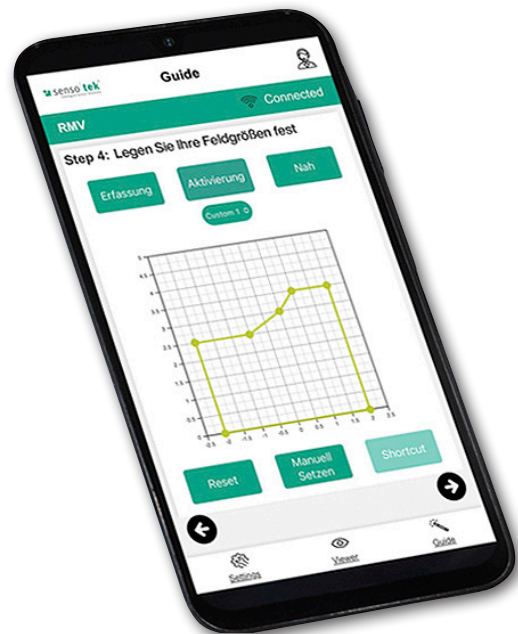

The operating principle is based on radar technology. The Radar MultiView RMV-G2 can be operated in all European countries. Proper use also includes observing the mounting and operating instructions. Any other or additional use is considered improper.



Improper use or unauthorized modifications of the product can result in danger to life and limb or damage to the product and other property. Use only original spare parts. The manufacturer/supplier is not liable for any consequential damages. The user himself is responsible for any risk.

Technical Data

General Specifications

Function principle	Measuring Radar with 3 operating ranges: Sensing range: determined by the mounting height Activation area: adjustable to application via software parameters Close area: adjustable to application via software parameters
Classification	Persons and vehicles
Assembly positions	Above the gate, in the middle, left or right; integrated mounting aid with IMU for all 3 spatial angles
Mounting height	Min. 2 m; max. 10 m
Detection speed	Min. 0.1 m/s, max. 8.0 m/s
Setting angle	Vertical: -90° ... +90°
Operating frequencies	24.150 GHz; can be switched to 24.050 GHz and 24.250 GHz; enables the operation of 3 radar units mounted close to each other
Radaröffnungswinkel	34° x 80°
Minimum sensing area Width x depth	f (H, d) indication via Interface
Cross-traffic suppression	Adjustable: on (100%, no triggering), middle (50%), off (0%)
Opening speed of the gate	Adjustable in [m/s]
Transmitter radiated power (EIRP)	< 20 dBm
Parameter setting	Via radio, WLAN (OTA), USB
Integrated temperature	°C / °F / °K, output via interface
Approvals and certificates	CE; UL

Indicators / Operating elements

Function indicator	1 x LED (rgb) Brightness: adjustable Ready for operation: LED flashes green - 10 s Ready for operation: LED is off, does not light up Approach: LED flashes yellow Output set: LED lights up red Parameterization: LED lights up blue, data connection established Error display: LED lights up white, flashing pattern
Control elements	None

Electrical specifications

Operating voltage	AC: 8 ... 35 V AC +/- 10% DC: 8 ... 45 V DC +/- 10%
Power consumption	< 2.5 W

Connections

2x outputs plus extension	1 x 8 pin socket
Expansion slot	1 x internal connector

Connection cable set

USB cable	2 m (not included in delivery)
cable, 8 pin plug	10 m (included in delivery)

Output

	All short circuit protected, normally open/closed (NO/NC), configurable via events
Signal output 1	Solid-state relay
Switching voltage 1	Up to 60 VAC/VDC
Switching current 1	Max. 0.5 A
Holding time 1	Adjustable in [s]
Signal output 2	Solid-state relay
Switching voltage 2	Up to 60 VAC/VDC
Switching current 2	Max. 0.5 A
Holding time 2	Adjustable in [s]

Events

	Events can be assigned to the outputs via parameter settings. Triggering in people; triggering for vehicles; triggering in combination; partial gate opening; fast opening; slow opening; counting of persons and/or vehicles; temperature control
--	--

Digital interface

ESP-NOW	Short range protocol, max. 25 m
----------------	---------------------------------

Technical Data

Ambient conditions

Special features	Resistance against weather and vibrations
Operating temperature	-40 ... 80° C (-40 ... 176° F)
Storage temperature	-40 ... 80° C (-40 ... 176° F)
Relative humidity	Max. 90% non condensing

Mechanical specifications

Degree of protection	IP67
Connection 1	8 pin socket
Housing	Polycarbonat (PC), anthrazit
Mass	650 g
Dimensions	131 mm x 73 mm x 136 mm

Parameter setting

Method	All parameters can be set via WEB-Interface and USB
Operating ranges	Activation area: which is inside the sensing range and can be defined as a polygon with max. 8 points. Near area: which is also inside the sensing range and can be defined as well with max. 8 points. The close area focus the gate to open in any case.

3. Installation

3.1 Installation

The product is preferably mounted above the automatic gates on the hinge/opposite hinge side.

Installation of the Radar MultiView RMV-G2:

The Radar MultiView RMV-DG can be installed at a height of approx. 300 mm above the automatic gate



Note: The maximum installation height H is measured from the floor and is not allowed to be exceeded.

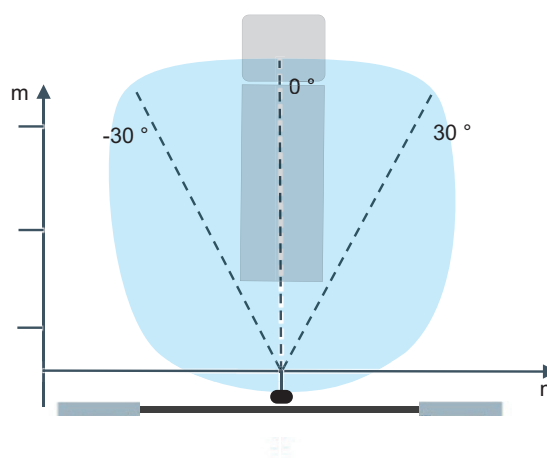

3.2 Wiring

The supplied wire harness must be used for wiring.

3.2.1 Connectors

8-Pin connector, male (Relay/IO plug):

- 1 = AC/DC IN
- 2 = AC/DC IN
- 3 = Relay 1 (NO/NC)
- 4 = Relay 1 (NO/NC)
- 5 = Relay 2 (NO/NC)
- 6 = Relay 2 (NO/NC)
- 7 = Extension 1
- 8 = Extension 2

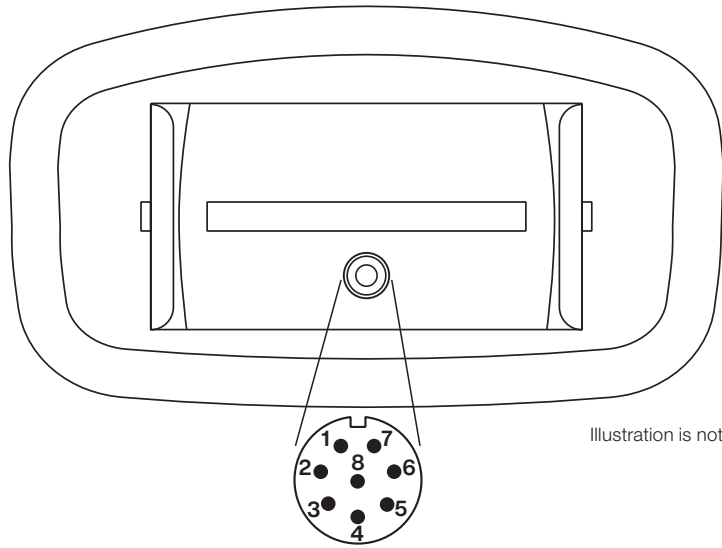
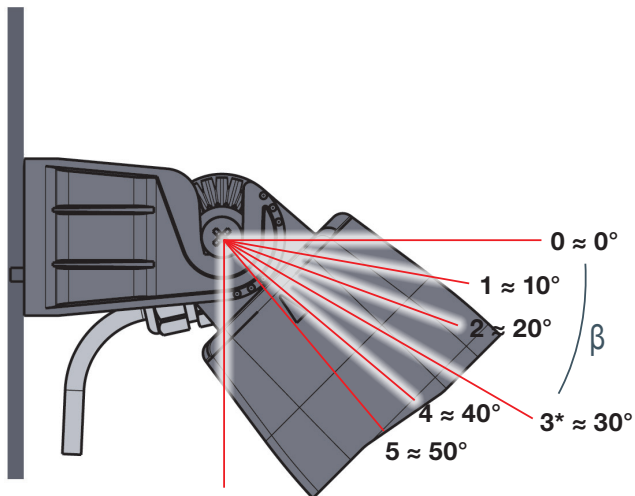

Illustration is not to scale

3.2.2 Wiring

Angle definition



Typical angle settings

4. Set-up

4.1 Function signaling

- 1 x LED (rgb) Brightness: adjustable
- Ready for operation: LED **flashes green** - 10 s
- Ready for operation: LED **is off**, does not light up
- Approach: LED **flashes yellow**
- Output set: LED **lights up red**
- Parameterization: LED **lights up blue**, data connection established
- Error display: LED **lights up white**, flashing pattern



4.2 Radar function areas

- **Detection area:** It is the possible field of view of the radar with its antenna.



Note: The maximum detection range is mainly determined by the installation height and the inclination angle.

- **Activation area:** Depending on the selected application there is an activation area within the detection area, in which **only** the opening function for the gate opening is generated.
- **Near area:** depending on the application there is also a near area within the activation area, in which a movement will lead to opening of the gate **in any case**.

4.3 Parameterization via the sensor's own web portal

The radar is operated using the configuration tool of the web server integrated in the radar in conjunction with a mobile device. The connection between the web server and the mobile device is established by scanning the QR Code shown on the housing or by entering the SSID printed on the housing in the web browser.



Note: The RMV-G2 does not work without parameterization via the web server, because the installation height must be entered via the web browser, for example, so that the RMD-G2 can determine its maximum detection range.

The configuration tool explains how to carry out the parameterization step by step.

4.4 Commissioning the radar

- The Radar RMV-G2 must be mechanically mounted above the gate. (see chapter 3)
- All cabling must be completed as per chapter 3.2. Check: After connecting voltage wires, the green RGB LED lights up for 10 seconds.
- Connecting to WLAN:



Note 1: The Radar WLAN is active for five minutes after applying voltage to the RMV-G2. RGB LED lights up blue.

Note 2: To activate WLAN, the "WLAN/BO" button must be pressed for five seconds until the RGB LED flashes purple.

4.4.1 Connecting the radar and mobile device

1. Automatically:

Scan the QR Code on the housing of the RMV-G2 with the camera of the mobile device. The mobile device, tablet/ smartphone immediately connects to the RMV-G2. The first menu is displayed: "Language selection".

2. Manually:

The SSID is noted on the housing of the RVM-G2. This must be selected from the list in the WLAN settings of the mobile device. Then enter the password printed on the cover. The tablet/smartphone connects to the RMV-G2. Open the web browser and enter "rmv.local" or alternatively "192.168.4.1". The RMV-G2 website is then loaded and is visible on the mobile device.

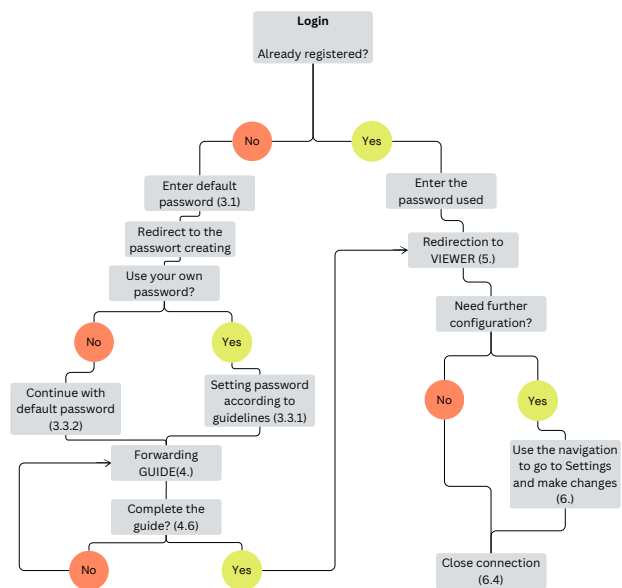

4.4.2 Settings on the web browser interface

1. Select language
2. Enter the password specified on the housing of the RMV-G2 radar
3. Assign a new password
4. Follow the device's instructions



Note: If you no longer have the login password, click on "Forgot password". You will be guided from here.

4.5 Angle setting

The angle setting has a significant impact on the detection range. The standard value should be an angle of inclination of approx. 30° when installing. The exact value can be set in conjunction with the user interface.

If the detection range shown in the configuration tool does not suit the application situation, the angle must be corrected accordingly using the locking lugs on the circuit board holder.

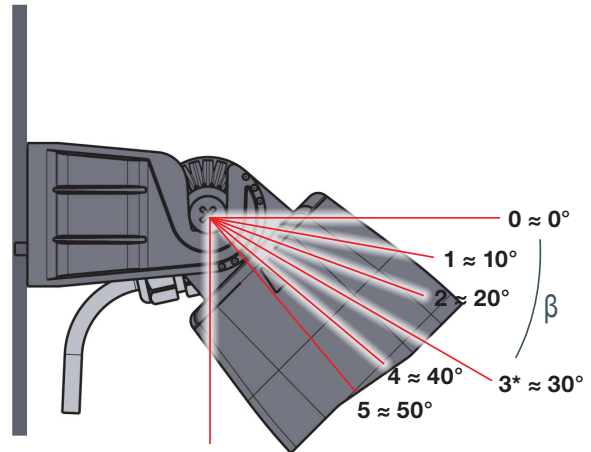

5. Operation

Once the configuration is complete, the Radar MultiView RMV-G2 is set up and ready for operation without any further adjustments. If during the final test after set-up the gate opens a little too early or too late, a fine adjustment for optimization with the potentiometer can be considered via the configuration tool.

5.1 Overview of LED display

LED – RGB	Description
LED flashes green – 10 seconds	Operational readiness
LED is off, no flashing	The sensor is ready for operation
LED flashes yellow	Approach detected in detection range
LED lights up red	Opening impulse set
LED lights up blue	Data connection is established
LED lights up white	Error display
LED lights up red purple	Activation of the WLAN

6. Maintenance

If the housing is heavily soiled, the radar housing shall be cleaned.

7. ESD safety



Device contains sensitive electronic components that are sensitive to electrostatic discharge (ESD). Use appropriate ESD protection such as wristbands to protect the device from damage.

8. Decommissioning



Device may be decommissioned only by trained personnel. Before dismantling, ensure there is no voltage.

9. Disposal



Device must be disposed in accordance with local regulations.
Electronic components must be recycled according to local regulations.